

Lemi[®]

ITALIAN WELLNESS EQUIPMENT



AESTHETIC SURGERY
DERMATOLOGY

CHIRURGIA ESTETICA
DERMATOLOGIA

LEMI 3



* M: Nefos 3962

Standard version / Versione standard



* M: Nefos 6



COD. 1160

Lemi 3 is equipped with high-performance and silent electronics and a practical standard foot pedal control. Wide mattress customization.

IDEAL FOR: diagnostics, check-up, dermatology and aesthetic surgery.

Lemi 3 è dotata di elettronica altamente performante e silenziosa e di una pratica pedaliera standard. Ampia personalizzazione del materasso.

IDEALE PER: diagnostica, check-up, dermatologia e chirurgia estetica.

** The images are for illustrative purposes only and may not reflect the actual image of the finishing.*

** Le immagini hanno valore puramente illustrativo e possono non rispecchiare l'immagine reale della finitura.*

Focus on

Standard foot pedal control

NEW

- Manual legrest, backrest and trendelenburg adjustment
- Fire retardant class 1IM, "Azo" free, antibacterial, antifungal covering
- Entirely enclosed ABS casing
- Fully customizable
- Standard version includes: 1 electric motor (height adjustment), foot pedal control and a flat mattress

Pedaliera standard

NEW

- Regolazione manuale di gamba, schiena e trendelenburg
- Rivestimento ignifugo classe 1IM, "Azo" free, antibatterico, antimicotico
- Carter in ABS completamente chiuso
- Totalmente personalizzabile
- La versione standard include: 1 motore elettrico (regolazione altezza) pedaliera e materasso piatto

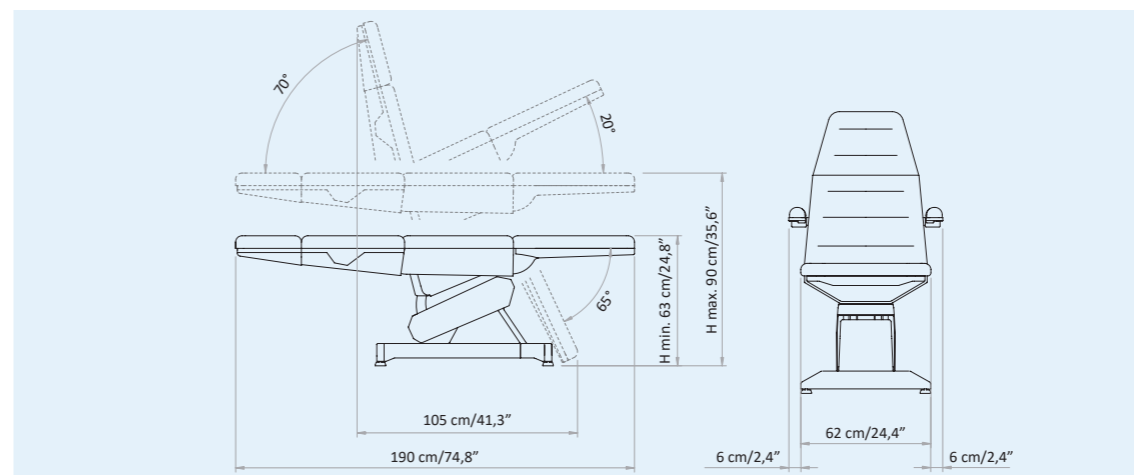

Packaging details

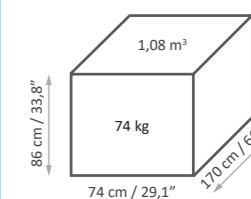

MAXIMUM CAPACITY
PORTATA MASSIMA
200 kg

STANDARD CONTROL

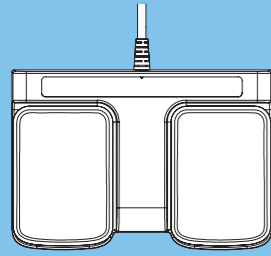

1 ELECTRIC
MOTOR



HIGH PERFORMANCE
SILENT ELECTRONICS

STANDARD CONTROL

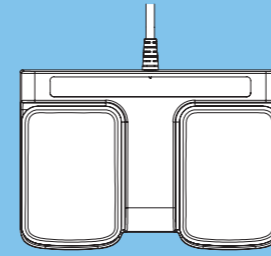

1 MOTORE
ELETTRICO



ELETTRONICA ALTAMENTE
PERFORMANTE E SILENZIOSA



Flat mattress
Materasso piatto

63-90 cm
(24,8"-35,6")

Electric height
Altezza elettrica



Manual legrest
Gamba manuale



65°

Manual Trendelenburg
Trendelenburg manuale

20°



Manual backrest
Schiena manuale

70°



Adjustable headrest
Testa regolabile

27°



LEMI 3 BI-ZAK



* M: Nefos 8009 Version with anatomic mattress and flat armrests / Versione con materasso anatomico e braccioli automatici



Adjustable footrest / Piede regolabile



Adjustable headrest / Testa regolabile

COD. 1161

Lemi 3 Bi-Zak is equipped with high-performance and silent electronics and a practical standard foot pedal control. Bi-Zak mattress with wide customization.

IDEAL FOR: diagnostics, check-up, dermatology and aesthetic surgery.

Lemi 3 Bi-Zak è dotata di elettronica altamente performante e silenziosa e di una pratica pedaliera standard. Materasso Bi-Zak con ampia possibilità di personalizzazione.

IDEALE PER: diagnostica, check-up, dermatologia e chirurgia estetica.

** The images are for illustrative purposes only and may not reflect the actual image of the finishing.*

** Le immagini hanno valore puramente illustrativo e possono non rispecchiare l'immagine reale della finitura.*

Focus on

▪ Standard foot pedal control

NEW

- Manual legrest, backrest and trendelenburg adjustment
- Fire retardant class 1IM, "Azo" free, antibacterial, antifungal covering
- Entirely enclosed ABS casing
- Fully customizable

▪ Standard version includes: 1 electric motor (height adjustment), foot pedal control, Bi-Zak flat mattress (adjustable headrest and footrest)

▪ Pedaliera standard

NEW

- Regolazione manuale di gamba, schiena e trendelenburg
- Rivestimento ignifugo classe 1IM, "Azo" free, antibatterico, antimicotico
- Carter in ABS completamente chiuso
- Totalmente personalizzabile
- La versione standard include: 1 motore elettrico (regolazione altezza) pedaliera, materasso Bi-Zak piatto (testa e piedi regolabili)

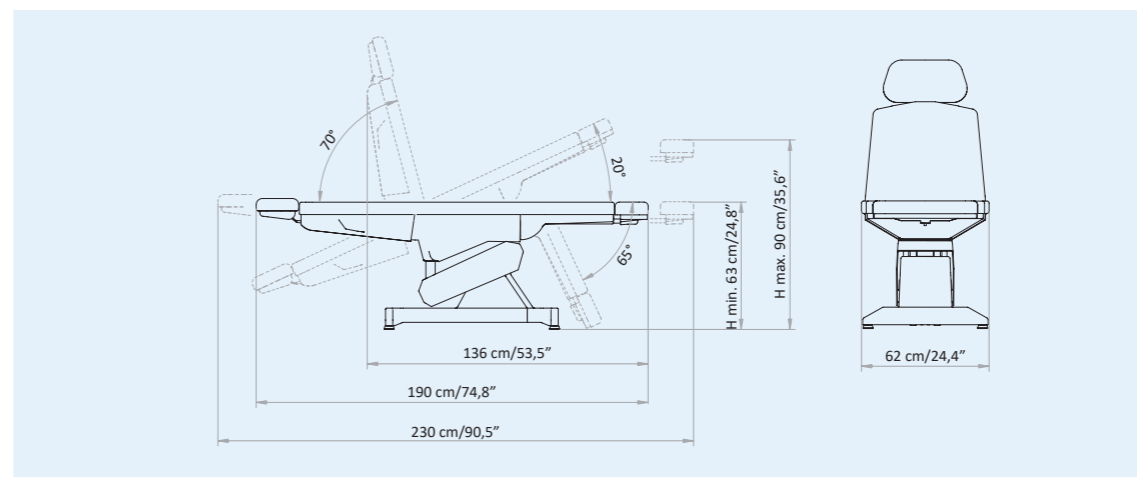

Packaging details

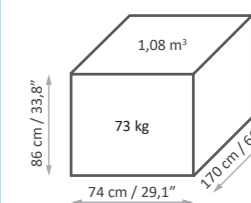

MAXIMUM CAPACITY
PORTATA MASSIMA
200 kg

STANDARD CONTROL

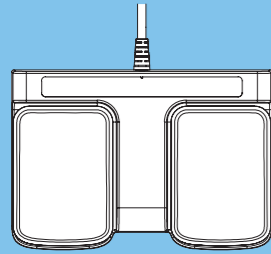

1 ELECTRIC MOTOR



HIGH PERFORMANCE SILENT ELECTRONICS

STANDARD CONTROL

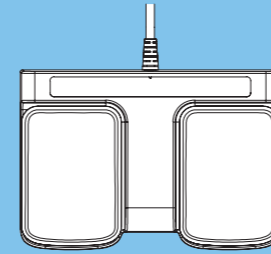

1 MOTORE ELETTRICO



ELETTRONICA ALTAMENTE PERFORMANTE E SILENZIOSA



Manually adjustable and removable Zak headrest

Testa Zak regolabile ed estraibile manualmente

63-90 cm
(24,8" - 35,6")



Electric height
Altezza elettrica



Manual backrest
Schiena manuale

70°



Manually adjustable and removable footrest

Piede regolabile ed estraibile manualmente

Manual Trendelenburg movement
Movimentazione Trendelenburg manuale



20°

Version with anatomic mattress and flat armrests
Versione con materasso anatomico e braccioli automatici



Manual legrest
Gambe manuali

65°

MATTRESS CUSTOMIZATION PERSONALIZZAZIONE MATERASSO



NEFOS - COLOR CHART

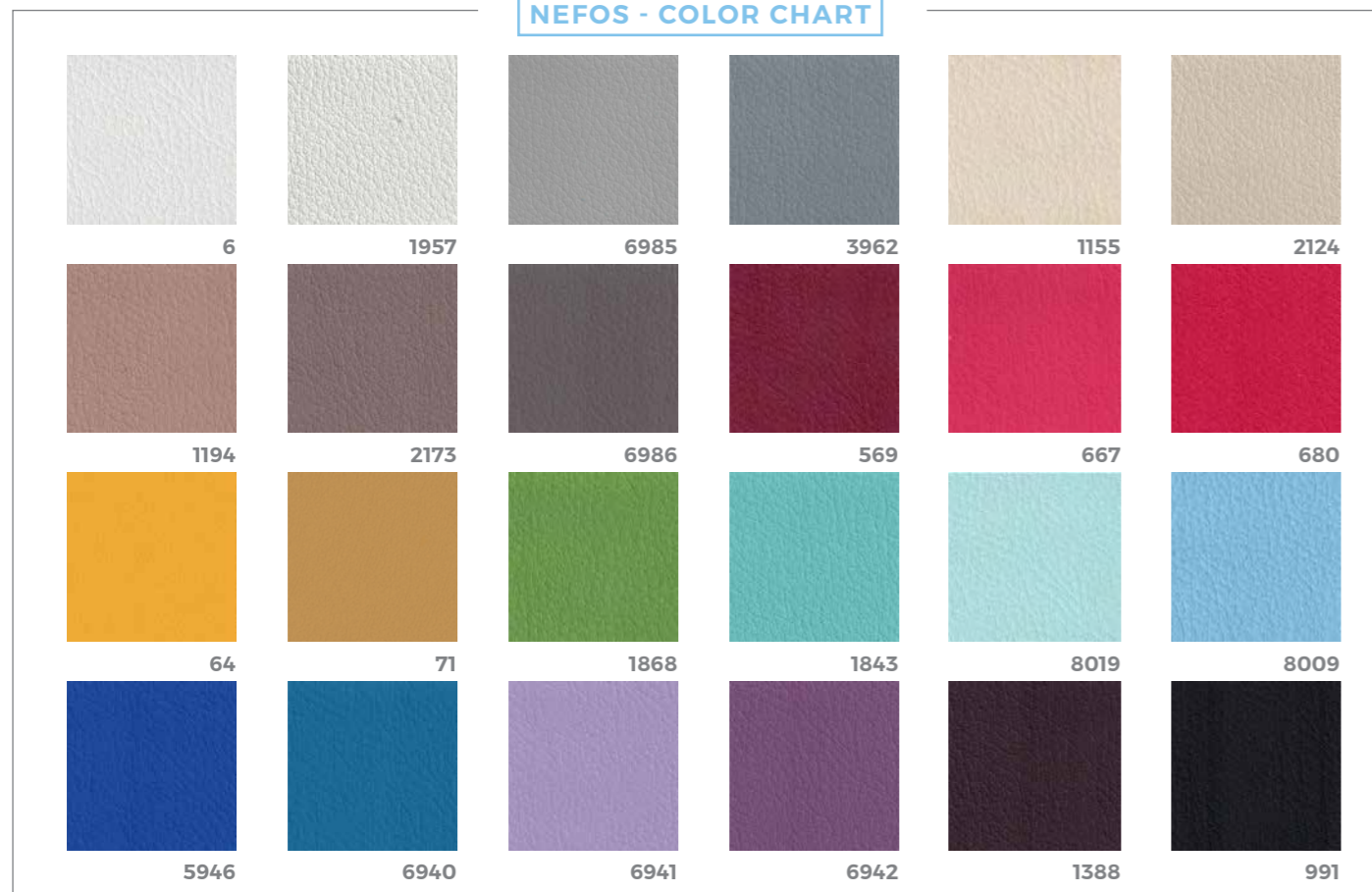

The innovative Nefos materials - which are exclusive for LEMI products - and their special finishing touch guarantee easy-cleaning and hygiene. Their extraordinary structural qualities will persist through the years. An incredibly elastic texture enhances the memory foam mattress softness and quality at its best.

Gli innovativi materiali Nefos - che sono un'esclusiva dei prodotti LEMI - ed il loro speciale tocco di finitura garantiscono una facile pulizia e igiene. Le loro straordinarie qualità strutturali permangono nel corso degli anni. Una texture incredibilmente elastica migliora al massimo la morbidezza e la qualità del materasso in Memory Foam.

The images are for illustrative purposes only and may not reflect the actual finish of the product, particularly when viewed through a screen. Therefore, the **SELECTION OF MATTRESS FABRICS** must take place **AFTER CONSULTING** the **PHYSICAL SAMPLES** of the **COLOR CHARTS**.

ANTIMICROBIAL TECHNOLOGY TECNOLOGIA ANTIMICROBICA

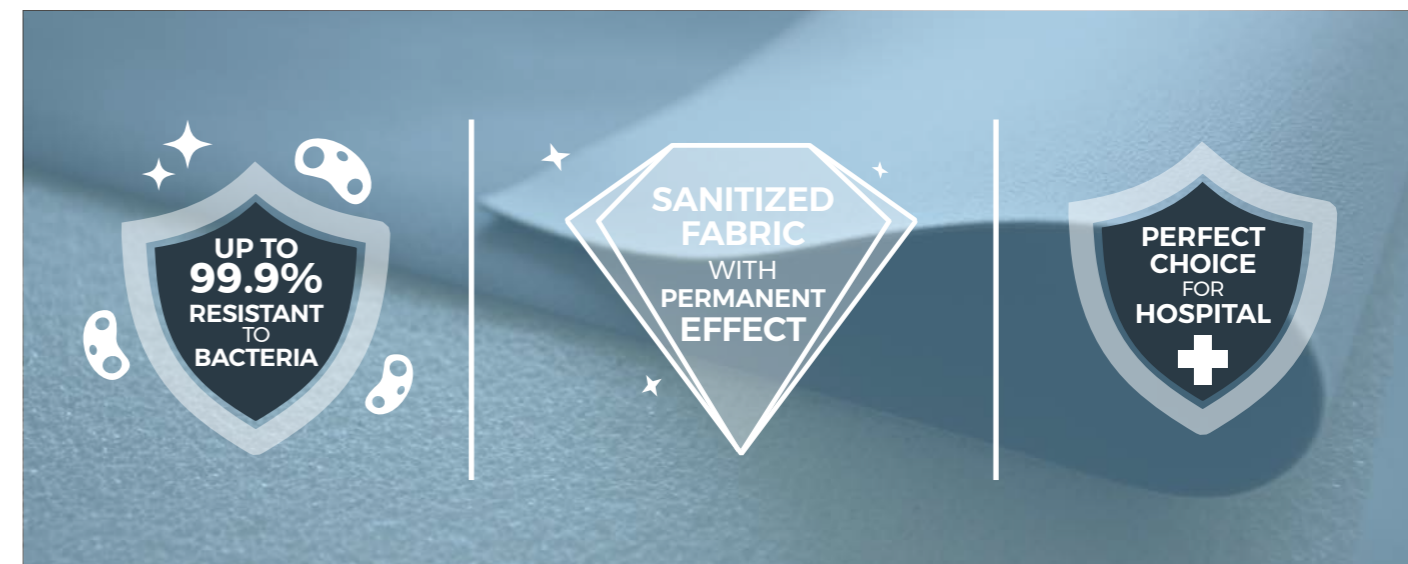

WHAT DOES IT MEAN?

The Nefos vinyl leather fabric is made through production processes involving an antimicrobial additive technology. Studies show that fabrics treated with this technology are up to 99.9% resistant to harmful bacteria.

The exceptional result that derives from it is a sanitized fabric with a permanent effect, whose matrix guarantees safety from any contamination thanks to the antibacterial, antifungal and anti-mold effect, which protects the coating from fungal attacks that can cause damage or bad smells, for the entire product's life cycle. The antimicrobial additive technology protects the fibers without changing their characteristics, thus preserving their freshness over time.

A high level of hygiene is essential, that's why this kind of technology was chosen by LEMI for all its bed and chair lines. The peculiarity of these coatings has allowed LEMI to give further value to its products, since thanks to this technology, the cleaning phase of Nefos vinyl leather fabric does not require the use of sanitizing products but requires the use of a soft cloth moistened and soapy, to be rinsed simply with clean water.

CHE COSA SIGNIFICA?

La linea di rivestimenti in vinilpelle Nefos è realizzata attraverso processi produttivi che coinvolgono una tecnologia additivante antimicrobica. Studi dimostrano che i tessuti trattati con questa tecnologia sono resistenti fino al 99,9% ai batteri nocivi.

Il risultato eccezionale che ne deriva è un tessuto igienizzato ad effetto permanente, la cui matrice garantisce sicurezza da eventuali contaminazioni grazie all'effetto antibatterico, antifungino e antimuffa, il quale protegge il rivestimento da attacchi micotici che possono essere causa di danni o di cattivi odori, per l'intera durata del ciclo di vita del prodotto. La tecnologia additivante antimicrobica protegge le fibre senza modificarne le caratteristiche, conservandone così la freschezza nel tempo.

Un alto livello di igiene è fondamentale, ecco perché questo tipo di tecnologia è stata scelta da LEMI per tutte le sue linee di poltrone e lettini. La peculiarità di questi rivestimenti ha permesso a LEMI di dare un ulteriore pregio ai propri prodotti, poiché proprio grazie a questa tecnologia, la fase di pulizia dei tessuti vinilpelle Nefos non necessita dell'utilizzo di prodotti igienizzanti ma prevede l'uso di un panno morbido inumidito e insaponato, da sciacquare semplicemente con acqua pulita.

Le immagini hanno valore puramente illustrativo e possono non rispecchiare la finitura reale del prodotto, in particolare se visualizzate attraverso uno schermo. Pertanto la **SELEZIONE** dei **RIVESTIMENTI** dei **MATERASSI** deve avvenire **PREVIA CONSULTAZIONE** della **CAMPIONATURA FISICA** delle **CARTELLE COLORI**.

BASE CUSTOMIZATION PERSONALIZZAZIONE BASE

ABS PLASTIC FINISHES



White
Bianco



Grey
Grigio



Black
Nero

We provide a thermoformed ABS base, completely closed to prevent any infiltration of powders or liquids. The result is a very strong material that is scratch resistant and easy to clean.

Forniamo una base in ABS termoformato, completamente chiuso per evitare qualsiasi infiltrazione di polveri o liquidi. Il risultato è un materiale molto robusto, resistente ai graffi e facile da pulire.

The images are for illustrative purposes only and may not reflect the actual finish of the product, particularly when viewed through a screen. Therefore, the **SELECTION OF THE FINISHES** of the **BASES** and **MATTRESS FABRICS** must take place **AFTER CONSULTING** the **LUXURY BOX PHYSICAL SAMPLES** and the **COLOR CHARTS**.

Le immagini hanno valore puramente illustrativo e possono non rispecchiare la finitura reale del prodotto, in particolare se visualizzate attraverso uno schermo. Pertanto la **SELEZIONE DELLE FINITURE** delle **BASI** e dei **RIVESTIMENTI** dei **MATERASSI** deve avvenire **PREVIA CONSULTAZIONE** della **CAMPIONATURA FISICA** della **LUXURY BOX** e delle **CARTELLE COLORI**.

ACCESSORIES UPON REQUEST ACCESSORI SU RICHIESTA

All chairs have a standard setting customizable upon request.

Tutte le poltrone hanno una configurazione standard personalizzabile su richiesta.



Flat armrest couple
Coppia braccioli automatici



ONLY FOR / SOLO PER LEMI 3 BI-ZAK
Small Zak headrest
Testa Zak piccola



ONLY FOR / SOLO PER LEMI 3 BI-ZAK
Strip headrest
Testa strip



ONLY FOR / SOLO PER LEMI 3 BI-ZAK
Anto headrest for hair transplant
Testa Anto per trapianto capelli



ONLY FOR / SOLO PER LEMI 3
Anatomic mattress
Materasso anatomico



ONLY FOR / SOLO PER LEMI 3 BI-ZAK
Anatomic Bi-Zak mattress
Materasso Bi-Zak anatomico



XL
Mattress XL
Materasso XL



Extra comfort mattress with
Memory Foam
Materasso extra comfort con
Memory Foam



Mattress without stitches
Materasso senza cuciture

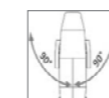

Option 180° rotation
Opzione rotazione 180°



Plastic leg protection
Proteggi gambe in plastica



Roll Holder (66 cm)
Roll Holder (75 cm) for XL mattress
Portarotolo (66 cm)
Portarotolo (75 cm) per materassi XL



Wheels with brake
Ruote con freno



Curtain holder (fixed with rotating
clamp and guides on the seat)
Reggitelo (da fissare con morsetto
girevole e guide schiena)



I.V. Rod (fixed with rotating clamp
and guides on the back)
Asta portaflebo (da fissare con
morsetto girevole e guide schiena)



Seat guide couple
Coppia guide seduta



Back guide couple
Coppia guide schiena



Fixed clamp
Morsetto fisso



Rotating clamp
Morsetto girevole



Blood sample taking armrest couple
(fixed with fix clamp and guides on
the seat)
Coppia braccioli da prelievo con
snodo (da fissare con morsetto fisso
e guide seduta)



Medical armrest couple (to be
fixed with rotating clamp and
guides on the back)
Coppia braccioli medicali
(da fissare con morsetti girevoli e
guide schiena)



Heel support couple (fixed with fix
clamp and guides on the seat)
Coppia reggitalone
(da fissare con morsetti fissi e
guide sulla seduta)



Thigh supports couple (fixed with
fix clamp and guides on the seat)
Coppia reggicose con snodo
(da fissare con morsetti fissi e
guide seduta)



Inox tray with support (fixed with
fix clamp and guides on the seat)
Vassoio inox completo di telaio
(da fissare con morsetto fisso e
guide seduta)



Hemo foot headrest
Supporto piede Hemo



UK cable
Cavo UK



USA cable
Cavo USA

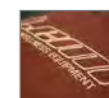

Customization with logo
Personalizzazione con logo

LEMI MATTRESSES STANDARD

Each mattress is HANDCRAFTED, therefore the ACTUAL MEASUREMENTS MAY VARY from those indicated in the catalogue by approximately ± 1 cm (also based on the selected configuration).

MATERASSI LEMI BI-ZAK

Ogni materasso è realizzato A MANO, pertanto le MISURE REALI POTREBBERO VARIARE rispetto a quelle indicate nel catalogo di circa ± 1 cm (anche in base alla configurazione selezionata).



FLAT

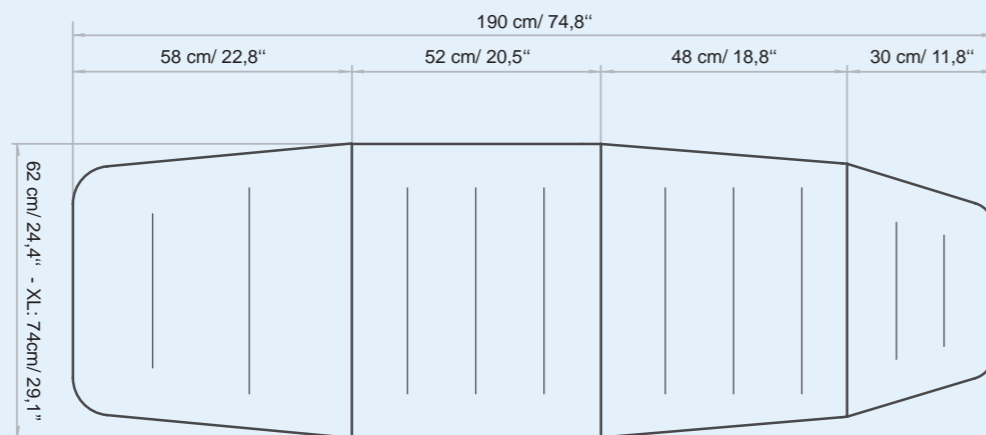

THICKNESS
SPESSORE
6cm | 2,4"

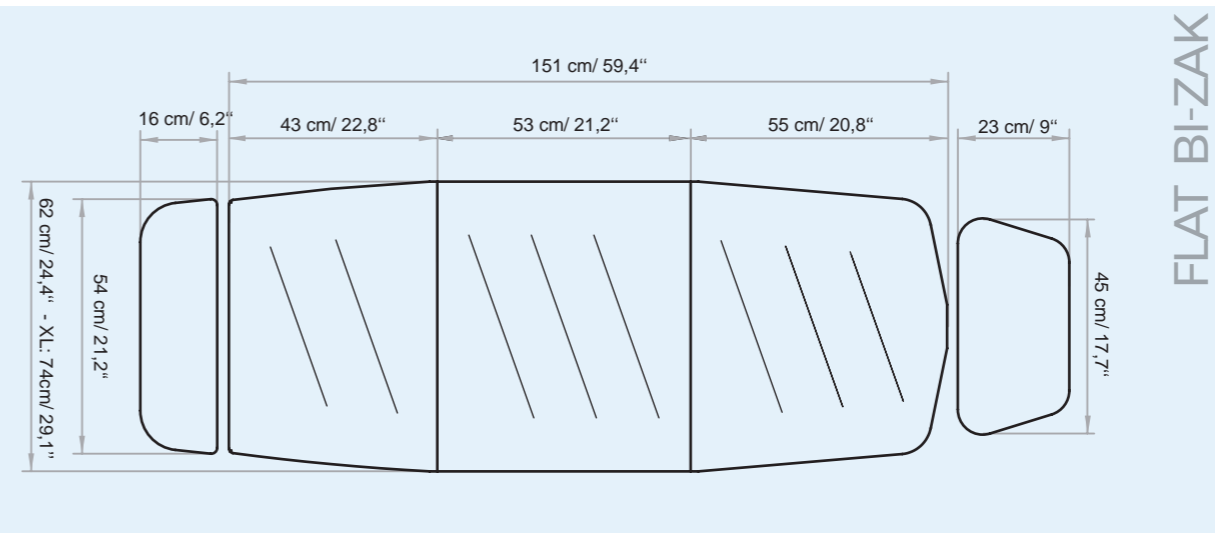

FLAT BI-ZAK

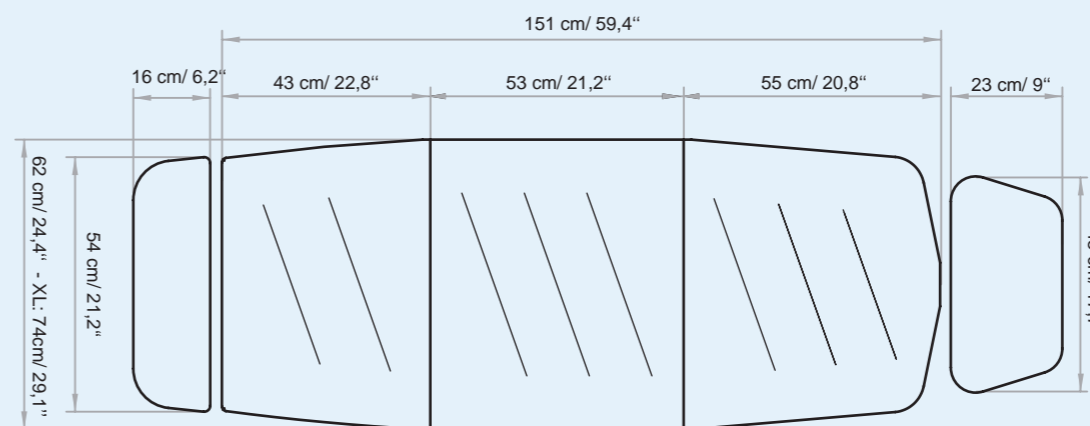

THICKNESS
SPESSORE
6cm | 2,4"



ANATOMIC

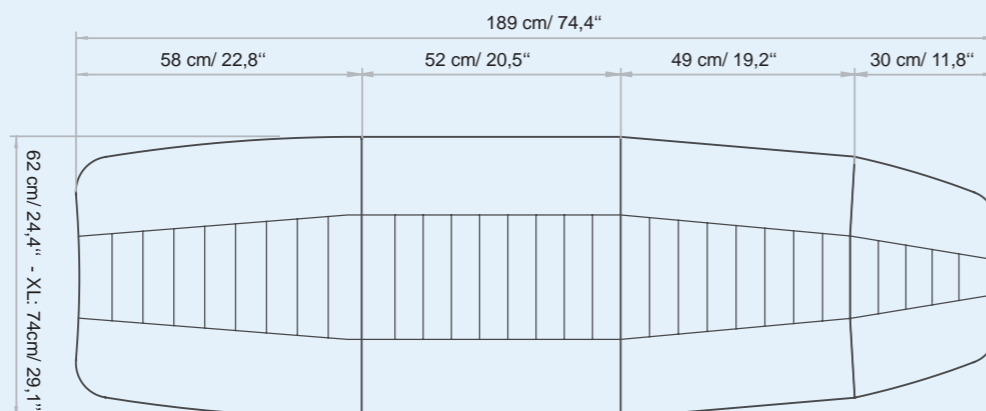

THICKNESS
SPESSORE
12cm | 4,7"

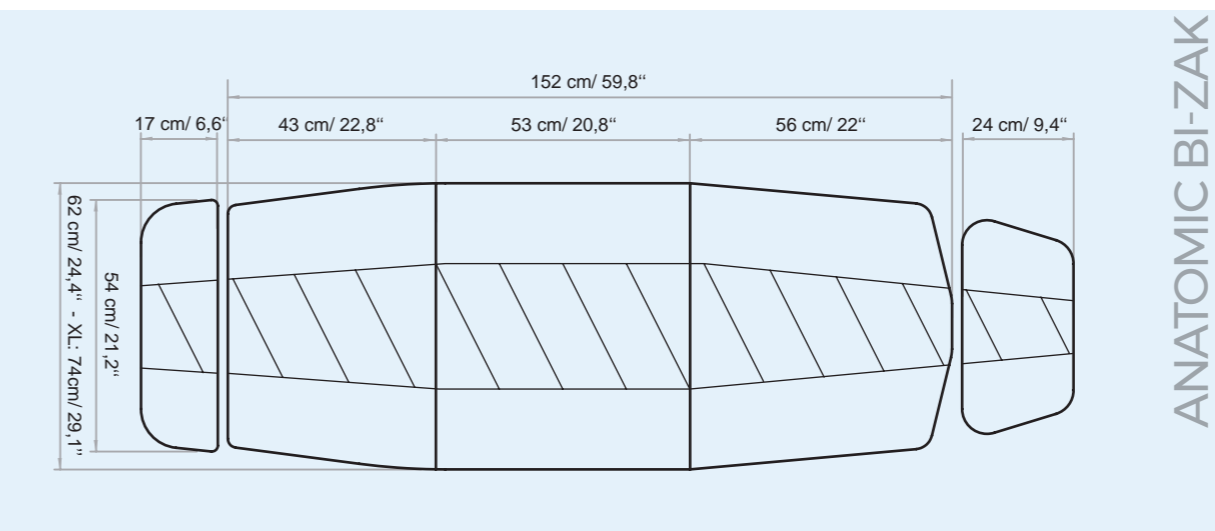

ANATOMIC BI-ZAK

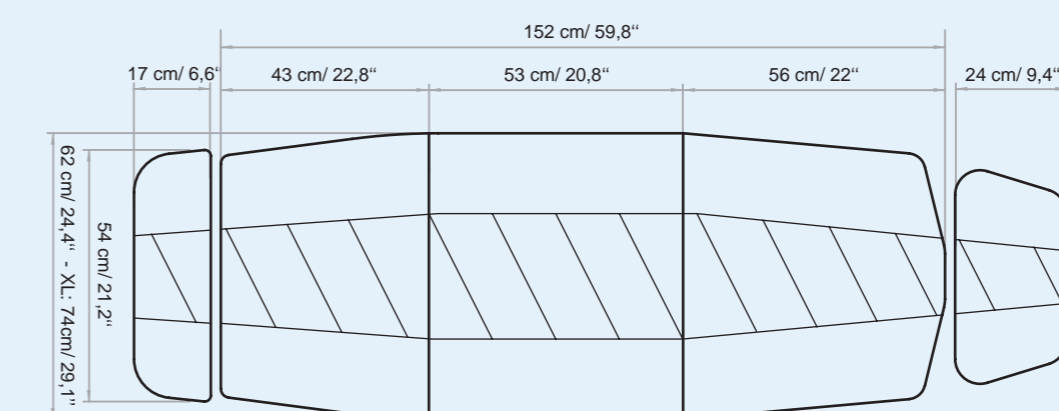

THICKNESS
SPESSORE
12cm | 4,7"



MEMORY

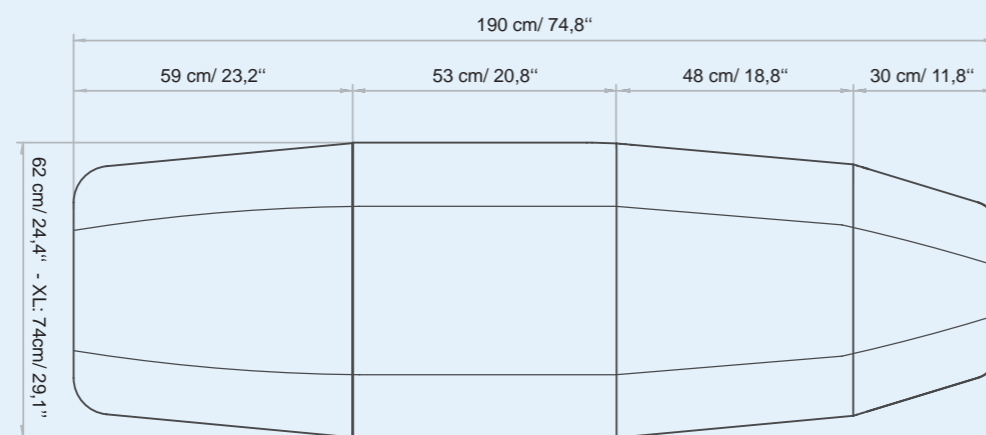

THICKNESS
SPESSORE
15cm | 5,9"

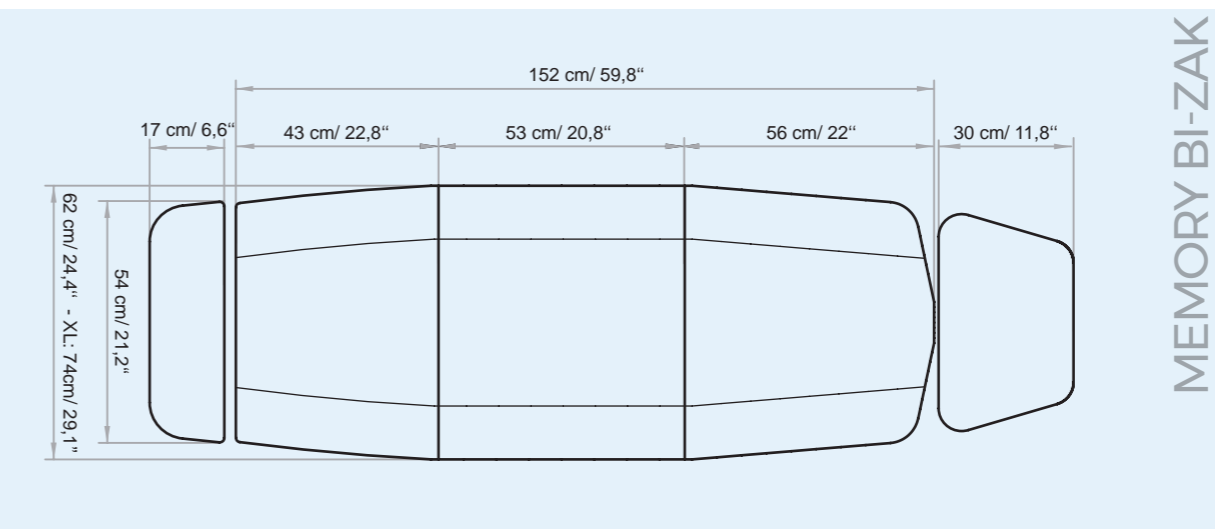

MEMORY BI-ZAK

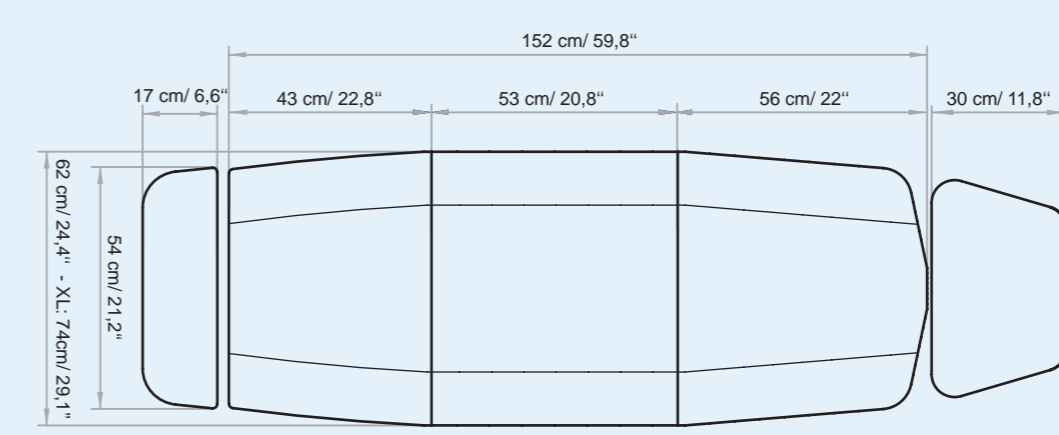

THICKNESS
SPESSORE
15cm | 5,9"

TECHNICAL REQUIREMENTS

CARATTERISTICHE TECNICHE

| ABSORPTION ASSORBIMENTO | VOLTAGE VOLTAGGIO | POWER POTENZA | FREQUENCY FREQUENZA | PROTECTION RATING GRADO DI PROTEZIONE | ELECTRIC SYSTEM CONFORMS TO CEI NORMS IMPIANTO ELETTRICO A NORME CEI | CONTROL BOX CENTRALINA |
|----------------------------|----------------------|------------------|------------------------|--|---|---------------------------|
| 1,5 Amax (0,6 A) | 100 Vac (240Vac) | 150W | 50/60 Hz | IP 54 | 60601-1 | CLASS II |

TECHNICAL SPECIFICATION / SPECIFICHE TECNICHE

MINIMUM HEIGHT: 63 CM / 24,8"

MAXIMUM HEIGHT: 90 CM / 35,6"

ANGLE OF INCLINATION TRENDELENBURG: 20°

ANGLE OF INCLINATION BACKREST: 70°

ANGLE OF INCLINATION LEGREST: 65°

ANGLE OF INCLINATION HEADREST: 27°

MATTRESS LENGTH: 190 CM / 74,8"

MATTRESS WIDTH: 62 CM / 24,4"

LATEX-FREE, NON-TOXIC AND NON-CARCINOGENIC MATERIALS

FIRE-RESISTANT UPHOLSTERY : UNI 9175 CLASS I M

ALTEZZA MINIMA: 63 CM

ALTEZZA MASSIMA: 90 CM

ANGOLO INCLINAZIONE TRENDELENBURG: 20°

ANGOLO INCLINAZIONE SCHIENA: 70°

ANGOLO INCLINAZIONE GAMBE: 65°

ANGOLO INCLINAZIONE TESTA: 27°

LUNGHEZZA MATERASSO: 190 CM

LARGHEZZA MATERASSO: 62 CM

MATERIALI PRIVI DI LATTICE, ATOSSICI E NON CANCEROGENI

RIVESTIMENTO IGNIFUGO: UNI 9175 CLASS I M

WARRANTY / GARANZIA

STRUCTURE: 10 YEARS

MOTORS AND CONTROL: 2 YEARS

CUSHION: 5 YEARS

STRUTTURA: 10 ANNI

MOTORI E CONTROLLI: 2 ANNI

MATERASSO: 5 ANNI

REGULATIONS

All Equipment is **CE** marked

Electrical equipment and beds

Directive 2006/42/CE (Machinery Directive) and national regulations
Directive 2014/30/UE (Electromagnetic Compatibility Directive) and national regulations.

Hydraulic equipment and beds

Directive 2006/42/CE (Machinery Directive) and national regulations

Images

The images are for illustrative purposes only and may not reflect the actual image of the product.

NORME

Tutte le attrezzature sono a marchio **CE**

Attrezzature e lettini elettrici

Direttiva 2006/42/CE (Direttiva Macchine) e disposizioni nazionali di attuazione
Direttiva 2014/30/UE (Direttiva Compatibilità elettromagnetica) e disposizioni nazionali di attuazione.

Attrezzature e lettini idraulici

Direttiva 2006/42/CE (Direttiva Macchine) e disposizioni nazionali di attuazione

Immagini

Le immagini hanno valore puramente illustrativo e possono non rispecchiare l'immagine reale del prodotto.

Lemi[®]
ITALIAN WELLNESS EQUIPMENT

Brusaferri & C srl

Via Mara Maretti Soldi, 13
26011 Casalbuttano (CREMONA) ITALY
Phone +39-0374-363069 Fax +39-0374-363071
info@lemigroup.it service@lemigroup.it

www.lemimd.com