

Monet Colouring Trolley  
06106  
Edition 1-2018

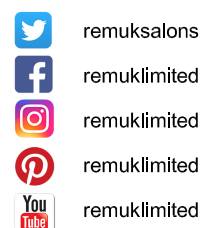

REM (UK) Limited  
Glenfield Mill,  
Glenfield Road,  
Nelson, Lancashire  
BB9 8AW  
T: +44 (0)1282 619 977  
F: +44 (0)1282 619 617  
E: sales@rem.co.uk  
W: www.rem.co.uk

Made in Britain 



Monet Colouring Trolley  
06106  
Edition 1-2018

**Product Name:** Monet Colouring Trolley

**Product Type:** Colouring Trolley

**Product Codes:**

- 06106 - Monet Colouring Trolley

**Standard Equipment:**

- Chrome stem with castor base
- Main tray
- 4 Accessory trays
- 1 Foil dispenser
- 1 Disposal Bin

**Optional Equipment:**

- N/A

**Main Construction:**

- High impact polypropylene

**Finish:**

- Available in black only

**Features:**

- A purpose-built colouring trolley
- Flat pack for customer assembly
- Compact design



Monet Colouring Trolley  
06106  
Edition 1-2018

NOTE: sizes may vary slightly from shown

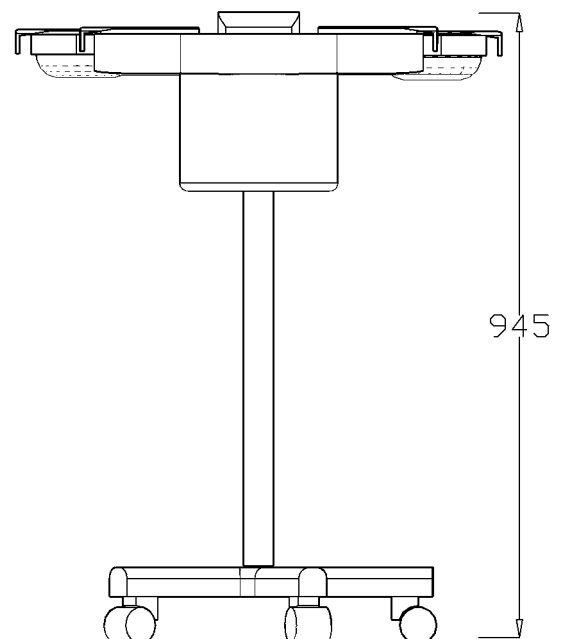
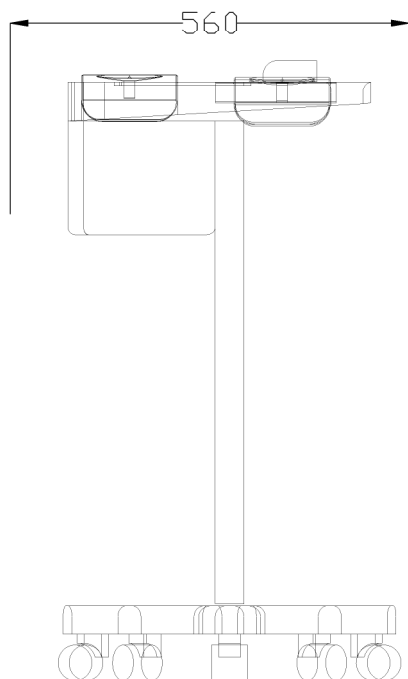
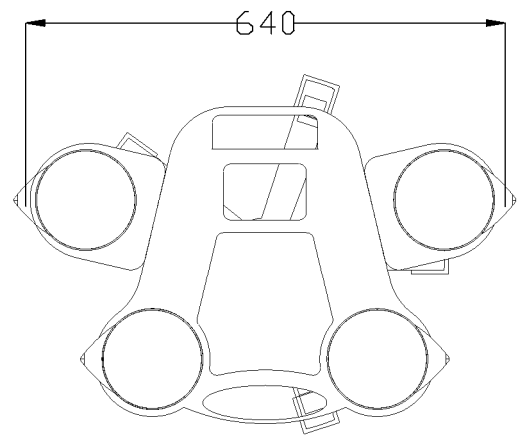
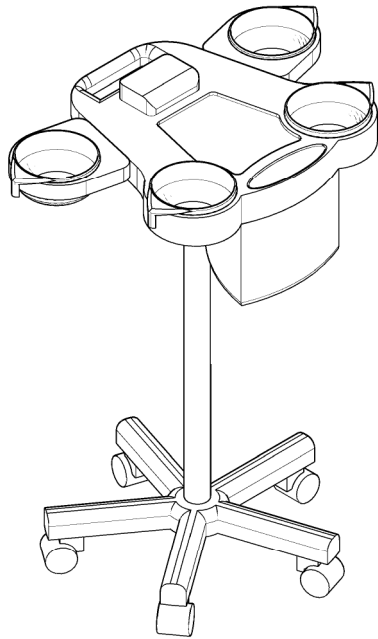

Monet Colouring Trolley  
06106  
Edition 1-2018

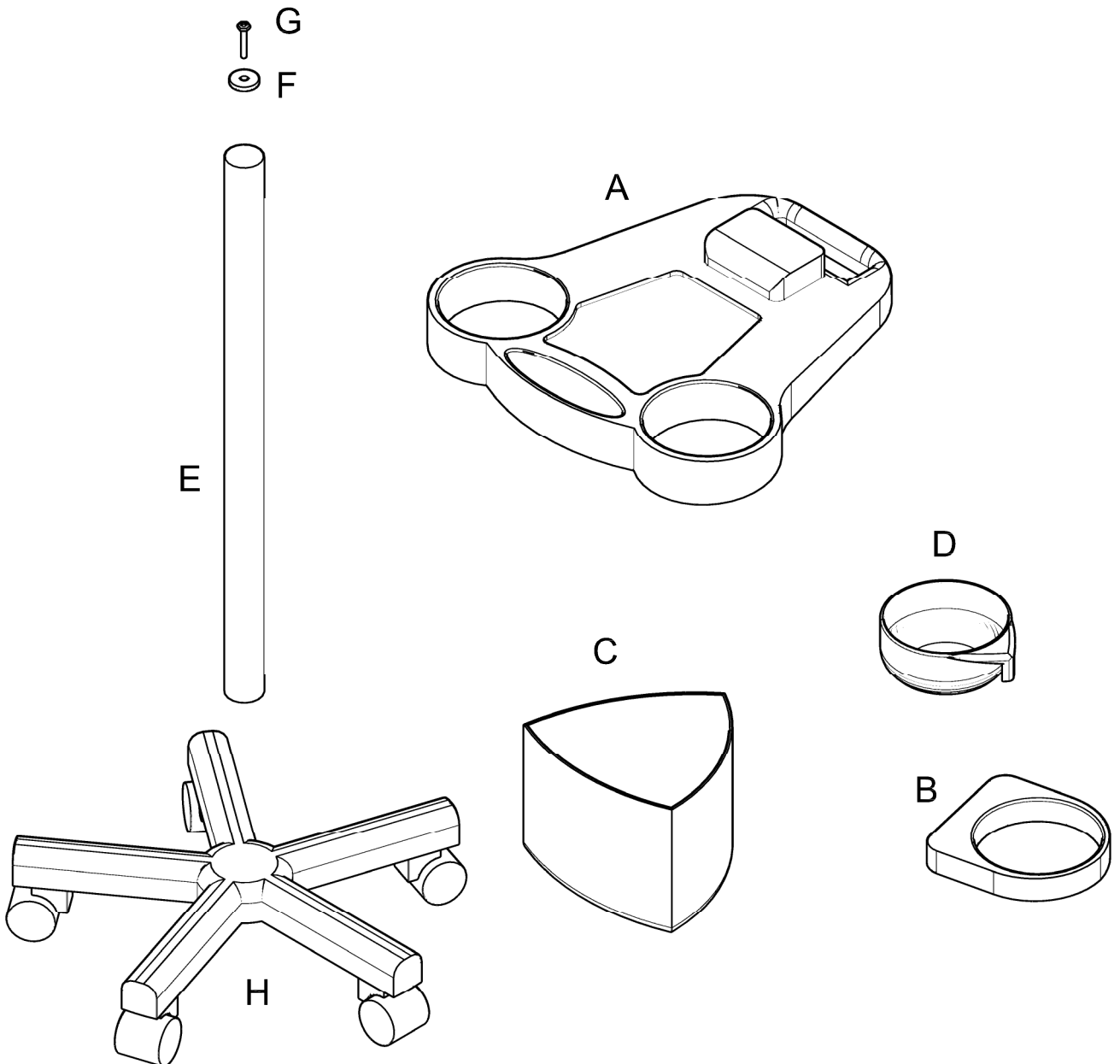

- A: Top Tray
- B: Side holders x 2
- C: Bin x 1
- D: Mixing bowls x 4
- E: Pole x 1
- F: Washer x 1
- G: Bolt x 1
- H: Base x 1

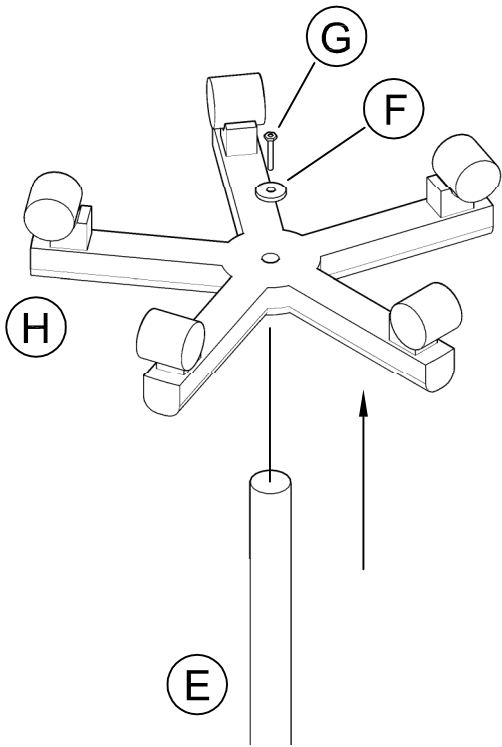

1. Push pole (E) into base (H). Using bolt (G) and washer (F) to assemble as shown.

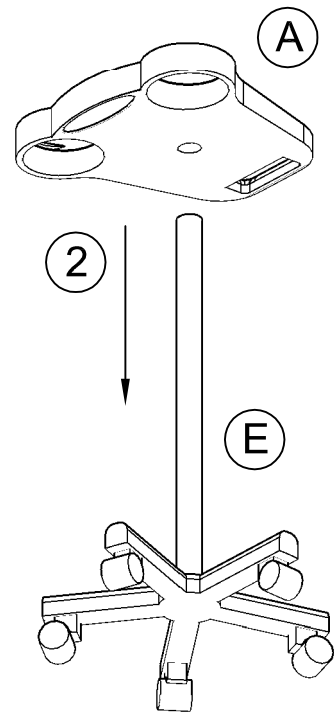

2. Place the Top Tray (A) onto Pole (E).

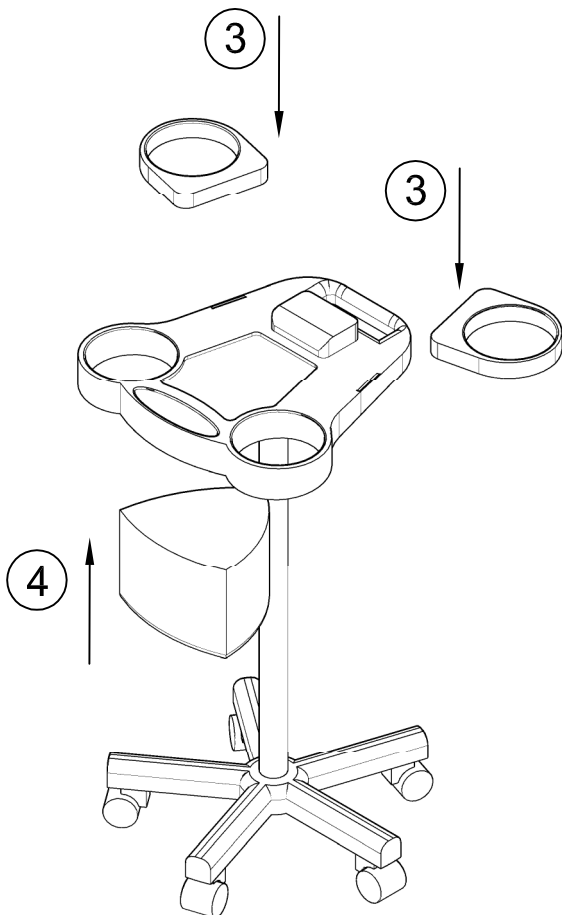

3. Slot side holders (B) on to Top Tray (A).

4. Push bin (C) into place.

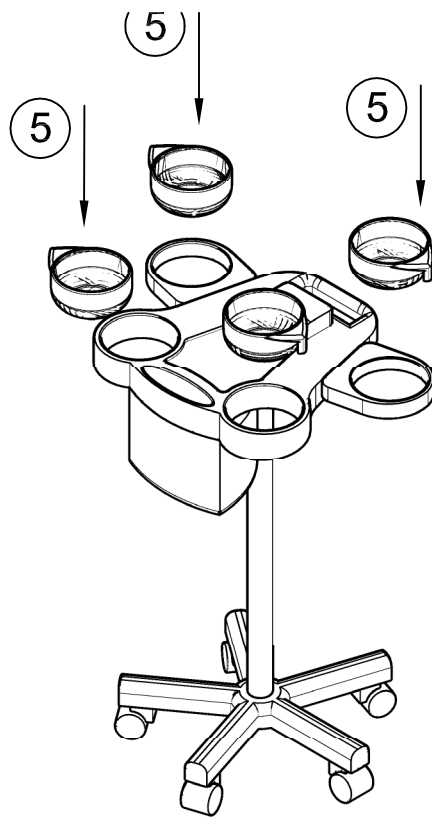

5. Put mixing bowels (D) in place.

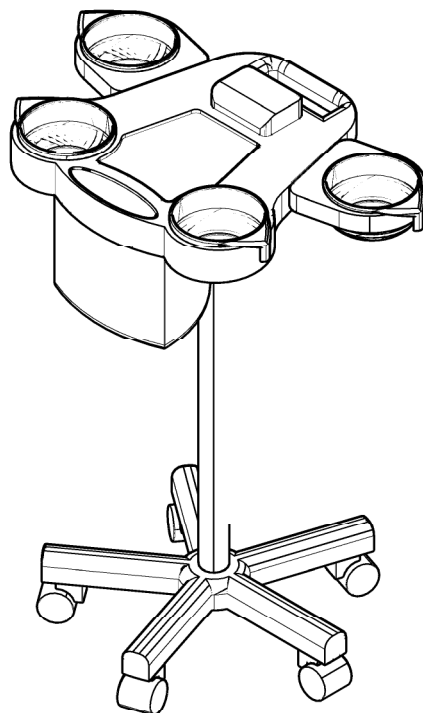

6. Monet Trolley complete

## **Fabrics:**

### **DECLARATION OF CONFORMITY OF CERTAIN FIRE RETARDANCY STANDARDS.**

BS 7176 is the British Standard which specifies the requirements for the resistance to ignition of upholstered furniture manufactured for seating or similar usage, but excluding use on domestic furniture or transport seating. Tests have been carried out on all REM products and fabrics in accordance to BS EN 1021-1: 2006 and BS EN 1021-2: 2006 which satisfy the performance requirements of Low Hazard Category of BS 7176 (resistance to ignition sources: Smouldering Cigarette and Match Flame Equivalent).

Typical examples of furniture that are required to meet the Low Hazard Category are Schools, Colleges, Offices, and Day Centres.

All of the cloths the REM swatch are available on the majority of REM products and meet the Medium Hazard Category (Public Buildings, Restaurants, Hotel Bedrooms, Hospitals etc) of BS 7176 which is similar to the above but also includes the Ignition Source 5 test of BS 5852: 2006.

It should be noted also, that whilst the test levels for the various hazard categories are set after careful consideration of the particular end-user environments involved, they are not intended to reflect the behaviour of the upholstery in a fully developed fire. A label is available for use on items produced in accordance with this standard, although there is no legal requirement to attach said label. These can be supplied on request at the time of ordering (printed to suit Low and Medium Hazard Only).

All products are subject to availability. REM reserves the right, without further notice, to alter the material specification of our products, if necessary to provide the highest levels of product quality.

## **Laminate:**

Each laminate shown in the REM swatch has been carefully selected from the Polyrey, Wilsonart & Egger Quality Collections of high pressure laminates (HPL). They can all be postformed (with the exception of Alu Brosse), and are suitable for commercial use. Please note that Matt Black has a tendency to fine scratching and finger marks when applied to horizontal working surfaces.

REM has made every effort to ensure that the Laminates presented in our swatch book are as the original. All products are subject to availability. REM reserves the right, without further notice, to alter the material specification of our products, if necessary to provide the highest levels of product quality.

Please ensure that you discuss any queries with our technical staff. For more colour ideas visit [www.rem.co.uk](http://www.rem.co.uk).

## **NOTE**

REM declines all responsibility for any injury to persons or damage to property caused by installation or assembly that has not been carried out in compliance with the general warnings, and the installation instructions of the pole/base and/or wall arm. REM declines all responsibility for any injury to persons or damage to property caused by installation or assembly carried out by non-qualified persons. REM declines all responsibility for injury or damage resulting from the unsuitability of the wall for the wall hood processor and arm only.

## **Environmental Protection**



The crossed-out wheeled bin symbol which you will find on the Rating Plate attached to your product, or appearing in the Assembly/Operating Instructions, signifies an obligation by you as purchaser or owner, to dispose of the equipment in accordance with the European Directive 2002/96/EC. This is a statutory instrument commonly known as the 'WEEE Regulations', which effectively requires you to carry out disposals of all Electrical and Electronic Equipment separately from your usual waste facilities. Specialist waste controls, designated by the Government (or Local Authorities) are to be made available to prevent potentially harmful substances affecting the environment and causing a possible human/animal health risk.

More detailed information is available from your local Environmental Health Office, Local Authority Waste Disposal Service, or the sales point from which the product was originally purchased.

REM's Producer Registration Number is **WEE/BJ0066TW**

## Guarantee

All REM products are supplied with a 3 Year Warranty from the date of purchase.

- *This Warranty Covers* any product defects arising from faulty materials or workmanship; or defects arising from transport damage. It is important to note that damages must be reported within 72 hours.
- *This Warranty Does Not Cover* any problems arising from damage caused by misuse, failure to install correctly, damage caused during 3rd party transportation and storage, or fair wear and tear.
- *This Warranty extends for a period of three years from date of purchase.* Customers must retain their receipt from the supplying REM Distributor as proof of purchase.
- *Throughout the first year of the warranty period* REM will, at its discretion, repair or replace defective products with both parts and labour covered under full warranty.
- *During the second and third year of the warranty period* REM will supply parts required for the repair free of charge but will not be responsible for any labour charges incurred to carry out the repair. These charges are the responsibility of the Customer.
- *REM will not be responsible for* any associated costs of refitting or reinstalling any products which have been replaced nor will it be responsible for any costs incurred arising from the non-availability of its products awaiting repair or replacement.
- *Should any problems arise with your REM product* please use the REM Support Link which is found at <http://www.remsupport.co.uk/>. The Customer Service Team can also be contacted at [customerservice@rem.co.uk](mailto:customerservice@rem.co.uk).
- *This three year warranty in no way affects your statutory rights* and is intended as an additional safeguard and benefit for buying and using REM products.

## REM Returns Policy

All defects arising from faulty materials or poor workmanship; or defects arising from transport damage will be returned to REM at no cost to the customer.

Where REM agree to replace a product, the replacement item will be charged to the customer's account. The returned unit will be credited in full once it has been received back at REM. In cases where the reported fault cannot be found, no credit will not be authorised.

Unwanted goods, or items not meeting customer requirements; which are free from the defects listed above and in its original packaging will be considered for credit by a duly appointed representative of REM. A minimum charge of £60 will apply and will be communicated before the returns order is processed.

**Please ensure that you discuss any queries with our technical staff:**

**www.rem.co.uk**

**sales@rem.co.uk**

**customerservice@rem.co.uk**

**+44(0) 1282 619 917**